

# Link Pin Ultimate Beam Install

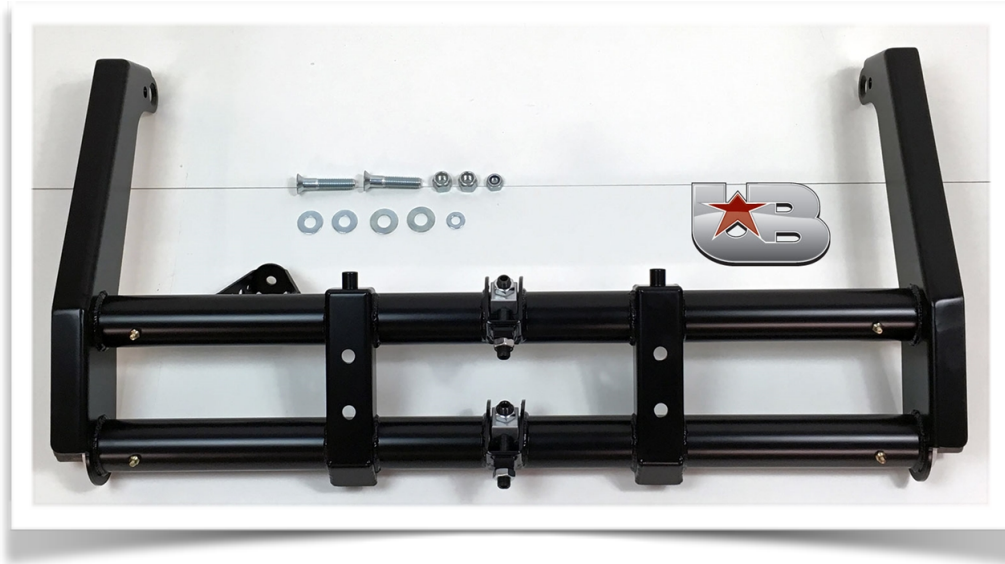

Congratulations on outfitting your ride with what we think is the best beam on the market.

1. Loosen the lug nuts 1/4 turn before jacking the vehicle up.
2. Jack up the front of the vehicle and place stands underneath the chassis.
3. Remove the wheels and place under the chassis as a fail safe.
4. Disconnect the battery.
5. Remove the dust cap, the spindle nuts and slide off the drum. On the driver's side remove the (3) bolts holding the backing plate onto the spindle and set to the side. Do not break loose any brake lines to avoid having to bleed the brakes afterwards.
6. To remove the spindle, you will need to remove the link-pin bolts on the back side of the spindle. When removing the spindle make sure that you don't get the shims mixed up and set them aside as inner and outer shims and upper to lower shims.
7. Remove the upper and lower control arms by removing the jam nuts and grub screws.
8. It is now time to remove the steering box. There is a steering shaft assembly that needs to be removed. I like removing the female steering shaft coupler on the steering box side of the assembly. Remove the 8mm bolt and nut and slide the column shaft towards the inside the car.
9. Remove the pitman arm bolt from the steering box.
10. Remove the (2) 17mm nuts/bolts that hold the steering box/clamp to the beam and remove from the vehicle.
11. Remove the shocks from the axle beam.
12. There are (4) 19mm bolts that hold the beam onto to the chassis and (2) that hold the body to the beam. If it is a pre-60 VW, those bolts are in the trunk area in front of

the gas tank. If it is a 61 and later VW, you will need to remove the 4 bolts holding the gas tank to the body. Clamp the fuel line and remove. Then remove the two bolts that are under the tank.

13. We recommend chasing the threads for proper engagement of the bolts. These bolts are threaded 12mm x 1.50.
14. It is now time to prep the new Ultimate Beam for installation. If you are going to use your old shocks, you will need to install them with the upper shock hardware provided. Make sure those are tight. Locate some plastic grocery bags and slide them over the shock towers. This will both save the paint from scuffing and from damaging the powder coat on the beam.
15. Slide the beam up and install the factory 4 bolts with washers loosely.
16. In 2016, we updated the beam uprights to have slots right to left to center the beam based on accidents and fender manufacturers. If you have the fenders on, measure from the tower edge to the outer fender edge on each side and center so that have the same measurement. Then tighten the bolts. You do not need to impact these on, nice and snug is fine. If you purchased the installation kit, the stainless ARP bolts will need a light coating of anti-seize on the threads before installing.
17. Lube the area on the steering box and clamp in place on to the beam aligning the pitman arm at the same time. Rotate the box to 22 degrees or centered towards the steering column. Tighten the bolts on the pitman arm and the steering box.
18. Install the steering dampener with the supplied hardware and factory bolt.
19. Lube the inside of the bushings with axle bearing grease.
20. If we did not supply the torsions for your project check out the tutorial on how to shorten your originals. Slide the torsions into the beam and index them in the square portion of the broached center. Slide them in to place with the cone point grub screw screwed in a few turns to keep the center from sliding down the beam. Once you have centered the torsions snug up the center grub screw. Once it is fully engaged install a jam nut and leave it loose for the time being.
21. You are now ready for your control arms. Inspect your control arms for wear. 9/10 times you will notice grooving where the original bearings will move metal when the torsions are under a load. You will need to file, pad sand, or use Emory cloth to smooth out these grooves. Polish to a smooth finish. Dry fit the control arms into each position. There should be some resistance but it should not take a hammer to get these control arms in. With beams after 6/10/10 you will not need a grease seal on your control arms as they are built into the bushings. Once you can slide them on



and off, apply some grease to the control arm and slide onto the torsions. We use [Valvoline grease found here](#).

22. Remove the center grub screw in the center and over rotate the arm to install the grub screws on the outer arms. Then install the jam nuts. Then do the opposite side. The reinstall the center grub screw, lube the aluminum slide block and install the jam nut hand tight.
23. Install the shocks onto the lower control arms.
24. It is time to install the spindles with link pins. Check out this diagram to install the correct amount of shims on each side.
25. It is now time to install the tie rods and ends. If you are using your factory ends, clean them up, paint them, [we use this paint](#), install the jam nuts and lube the threads. Important fact that most retailers selling cheap tie rod ends will try and sell you the wrong inner tie rod ends. For the inner tie rod ends the left side inner on a LHD car actually has a small bend on it. If your left side inner does not have this angle, [get one here](#). The right side inner is set up for a steering dampener tie rod end. Spin the ends into the tie rods until they are bottomed out. Install the tie rods and leave the nuts loose on the pitman arm and spindles.
26. Rotate the steering wheel left to right and count the revolutions. Rotate the steering wheel right to left exactly 1/2 the amount of revolutions. The steering box is now centered. You should have exactly the amount of turns to the right as you have to the left. If you don't, your steering box was not centered properly. If your steering wheel is no longer straight, you will need to pop the wheel off and reposition it straight.
27. Install your brakes in the reverse order of removal. When tightening the spindle nuts, tighten until the drum no longer spins with force, then back off 1/4 turn.
28. Lube your speedo cable so it can pass through the spindle and protrudes past the spindle shaft. Place the dust cap over the cable and install the eClip and tap the cap on until it bottoms out. Install your wheels and snug the lug nuts up.
29. Lower the vehicle on the ground. It is now time to adjust the height of the car. Take a measurement from the ground to the fender edge and write it down. Make a note of where you would like the fender to be. Now you can back out the center adjuster bolts slowly counting the amount of turns and making sure that the upper and lowers

**Arrangement of Shims on Torsion Arm Link Pins**

| Offset<br>in mm | Number of Shims for |                 |                   |                 |
|-----------------|---------------------|-----------------|-------------------|-----------------|
|                 | Upper Torsion Arm   |                 | Lower Torsion Arm |                 |
|                 | Inner Shims (A)     | Outer Shims (B) | Inner Shims (C)   | Outer Shims (D) |
| 5,5             | 2                   | 6               | 5                 | 3               |
| 6               | 2                   | 6               | 4                 | 4               |
| 6,5             | 3                   | 5               | 4                 | 4               |
| 7               | 3                   | 5               | 3                 | 5               |
| 7,5             | 4                   | 4               | 3                 | 5               |
| 8               | 4                   | 4               | 2                 | 6               |
| 8,5             | 5                   | 3               | 2                 | 6               |

**Note:**

- a - There must always be 8 shims and one retainer with dust excluder fitted to each torsion arm link pin.
- b - If the offset is 7 mm B and D have 5 shims each and A and C 3 each.
- c - If the offset is in excess of 7 mm, shims should be added to A and removed from C.
- d - If the offset is below 7 mm, shims should be removed from A and added to C.
- e - Number of shims at B and D should always be brought up to 8.

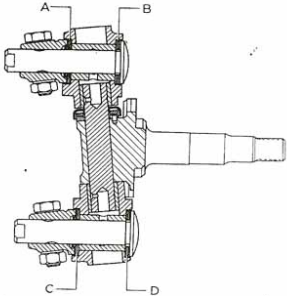

V-5  
2

are even. Understand that each thread can make the car drop a 1/4" roughly so take it slow to get it right. Once you have the ride height where you want it snug up all the adjusters jam nuts.



- 30. Now it is time to get the alignment close. Adjust the tie rods until the tire look parallel to the fenders on each side. Take a measurement from the front of the tires from the same place on each tire. Then take a measurement on the back of the tires from the same tread you measured from on the front. Adjust to make the measurements the same. This is a rough alignment. It is always recommended to have an alignment specialist do a 4 wheel one digitally to ensure your tires will wear evenly.
- 31. Once this is done take a grease gun with a new grease tube and pump a full tube of grease into the four zerks evenly. Remember when taking apart your VW in the first place, your VW was caked with grease. These cars need lube to work properly. Wipe off the excess grease from any area it has secreted from. It is recommended that each time you do a valve adjustment or oil change to pump those zerks with a couple pumps each to ensure that they are properly lubed at all times.

Your car should ride really nice with the Ultimate Beam properly installed. If it does not please contact us so we can go over the symptoms you have.



Once you have your ride height dialed, measure how much of the threads are showing on the bottom adjustment bolt, from the face of the jam nut to the end of the adjustment bolt. Remove the bolt and cut that amount off the end that does NOT have the allen hole in it. Taper the end smoothly and apply some anti-sieze or grease to the adjustment bolt and screw it back in so that it is flush to the nut. This will give you even more ground clearance.

## TOOLS

The PRO's want to make it as easy as possible to do the job right. To do that, you need the right tools and assembly products ready to go when your suspension purchase from Airkewld arrives at your door. All these products are available at Amazon so they are just a few days away from receiving them.

|                              |                      |   |
|------------------------------|----------------------|---|
| Emory Cloth - Polishing Arms | <a href="#">Link</a> |  |
| Anti-Seize - Adjuster Bolts  | <a href="#">Link</a> |  |

|                         |                      |   |
|-------------------------|----------------------|---|
| Grease Gun              | <a href="#">Link</a> |    |
| Rubber Dead Blow Hammer | <a href="#">Link</a> |    |
| Degree Finder           | <a href="#">Link</a> |    |
| Torque Wrench           | <a href="#">Link</a> |    |
| Loctite                 | <a href="#">Link</a> |   |
| Assembly Lube           | <a href="#">Link</a> |  |
| Impact Drill            | <a href="#">Link</a> |  |
| Floor Jack              | <a href="#">Link</a> |  |

|                   |                      |   |
|-------------------|----------------------|---|
| Jack Stands       | <a href="#">Link</a> |  |
| Bendpack Car Lift | <a href="#">Link</a> |  |

## Manuals

|                        |                      |   |
|------------------------|----------------------|---|
| How to restore your VW | <a href="#">Link</a> |    |
| Idiot Book             | <a href="#">Link</a> |   |
| Bentley                | <a href="#">Link</a> |  |
| Haynes 54-79           | <a href="#">Link</a> |  |
| Chilton 49-69          | <a href="#">Link</a> |  |